



QUARTER SCALE AUTO CLUB, Inc.

Website <http://www.qsac.org>



OFFICIAL 2022 QSAC DIRT TRACK RULES ADDENDUM

Copyright © 2003-2022 [QSAC, Inc.] All rights reserved.
Other products and companies referred to herein are trademarks
or registered trademarks of their respective companies or mark holders

Welcome to the OFFICIAL 2022 QSAC DIRT TRACK RULES ADDENDUM

1. QSAC STATEMENT AND TECHNICAL COMPLIANCE RESPONSIBILITY

- 1.1. Unless otherwise specified in this addendum, please refer to the 2022 QSAC Rules Package for all technical and class-specific specifications.
- 1.2. When there is a conflict or discrepancy between the 2022 QSAC Rules Package and the 2022 QSAC Dirt Track Rules Addendum, the 2022 QSAC Rules Package shall take precedent and priority over this dirt track rules addendum.

2. DIRT TRACK CLASSES

- 2.1. East Coast Modified (ECM)
- 2.2. Sprint Car
- 2.3. Super-Truck

3. ENGINE SPECIFICATIONS

- 3.1. Unless otherwise specified, all engine specifications from the 2022 QSAC Rules Package, Section 8, GENERAL SPECIFICATIONS apply to all dirt track classes.

4. TIRE SPECIFICATIONS

- 4.1. General tire rules for ALL classes running on dirt:
 - 4.1.1. Tires may ONLY use checkerboard, ribbed, or street bands.
 - 4.1.2. Spiked tires are NOT allowed.
 - 4.1.3. Grooving of tires is NOT allowed.
 - 4.1.4. Homemade tires and/or bands are NOT allowed.
 - 4.1.5. Cleaning or washing of dirt track racing tires is allowed.
 - 4.1.5.1. Tires may **ONLY** be cleaned with **WATER**.
 - 4.1.5.2. Soap, detergent or chemical agents are **NOT** allowed.
 - 4.1.5.3. Traction additives are **NOT** allowed.

QSAC USE ONLY - DO NOT COPY

4.2. Class specific tire rules

4.2.1. OVERVIEW: The following view is a cross-section(s) of a wheel, host and tread.

Class specific sizes and tolerances are listed in the charts in sections 4.2.2., 4.2.3., and 4.2.4.

NOTE: THE CROSS SECTION IS GENERIC AND APPLIES TO ALL CHARTS FOR ALL CLASSES.

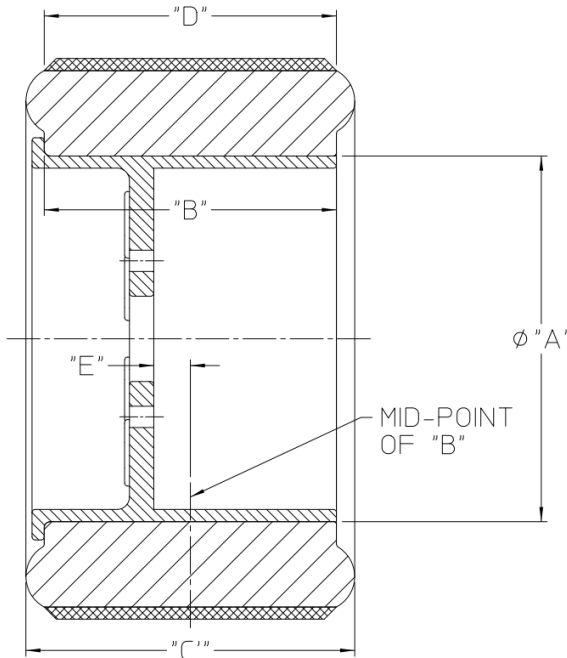

4.2.2. EAST COAST MODIFIED (ECM): The following chart defines the allowable sizes for wheel, host and tread in the ECM Class.

ECM	"A" (WHEEL DIA)	"B" (WHEEL WIDTH)	"C" (HOST)	"D" (TREAD)	"E" (OFFSET)
LEFT FRONT	3.50" - 4.00"	2.00" - 3.00"	2.00" - 3.75"	2.00" - 3.25"	1.00" MAX
LEFT REAR	3.50" - 4.00"	2.50" - 3.00"	2.50" - 3.75"	2.75" - 3.25"	1.00" MAX
RIGHT FRONT	3.50" - 4.00"	2.00" - 3.00"	2.00" - 3.75"	2.00" - 3.25"	1.00" MAX
RIGHT REAR	3.50" - 4.00"	3.00" - 4.00"	3.00" - 4.75"	3.00" - 4.00"	1.00" MAX

4.2.3. SPRINT CAR: The following chart defines the allowable sizes for wheel, host, and tread for the Sprint Car class.

SPRINT CAR	"A" (WHEEL DIA)	"B" (WHEEL WIDTH)	"C" (HOST)	"D" (TREAD)	"E" (OFFSET)
LEFT FRONT	3.50" - 4.00"	2.00" - 2.75"	2.00" - 3.25"	2.00" - 2.75"	1.00" MAX
LEFT REAR	3.50" - 4.00"	2.50" - 3.00"	2.50" - 3.75"	2.50" - 3.25"	1.00" MAX
RIGHT FRONT	3.50" - 4.00"	2.00" - 2.75"	2.00" - 3.25"	2.00" - 2.75"	1.00" MAX
RIGHT REAR	3.50" - 4.00"	3.00" - 4.00"	3.00" - 4.75"	3.00" - 4.00"	1.00" MAX

4.2.4. SUPER-TRUCK: The following chart defines the allowable sizes for wheel, host, and tread for the Super-Truck class.

SUPER-TRUCK	"A" (WHEEL DIA)	"B" (WHEEL WIDTH)	"C" (HOST)	"D" (TREAD)	"E" (OFFSET)
LEFT FRONT	3.50" - 4.00"	2.00" - 3.00"	2.00" - 3.75"	2.00" - 3.25"	1.00" MAX
LEFT REAR	3.50" - 4.00"	2.50" - 3.00"	2.50" - 3.75"	2.75" - 3.25"	1.00" MAX
RIGHT FRONT	3.50" - 4.00"	2.00" - 3.00"	2.00" - 3.75"	2.00" - 3.25"	1.00" MAX
RIGHT REAR	3.50" - 4.00"	2.50" - 3.00"	2.50" - 3.75"	2.75" - 3.25"	1.00" MAX

5. BODY, WING, AND SPOILER SPECIFICATIONS

5.1. SPRINT CAR:

5.1.1. TOP WING:

5.1.1.1. The top wing of a dirt track sprint car will follow all of the specifications outlined in section 14.6 of the QSAC Rules Package with the following exceptions.

5.1.1.1.1. Overall width may be 15" Max.

5.1.1.1.2. The overall width measurement includes the side dams and any bends in the side dams.

5.1.1.1.3. See Image below labeled TOP WING -DIRT TRACK.

5.1.2. WICKER BILL:

5.1.2.1. The Wicker Bill for the Top Wing of a dirt track sprint car will follow all of the specifications outlined in section 14.8 of the QSAC Rules Package with the following exceptions.

5.1.2.1.1. The Wicker Bill is not required to maintain a 90 degree angle relative to the trailing edge of the wing.

5.1.2.1.2. If the Wicker Bill is not 90 degrees to the trailing edge of the wing and extends beyond the end of the trailing edge of the top wing, the length of the Wicker Bill WILL BE INCLUDED in the 16" Max overall top wing chord length measurement.

5.1.3. BODY:

5.1.3.1. The body of a dirt track sprint car will follow all of the specifications outlined in section 14.9 of the QSAC Rules Package with the following exceptions.

5.1.3.1.1. Use of a belt/gear guard is allowed.

TOP WING - DIRT TRACK

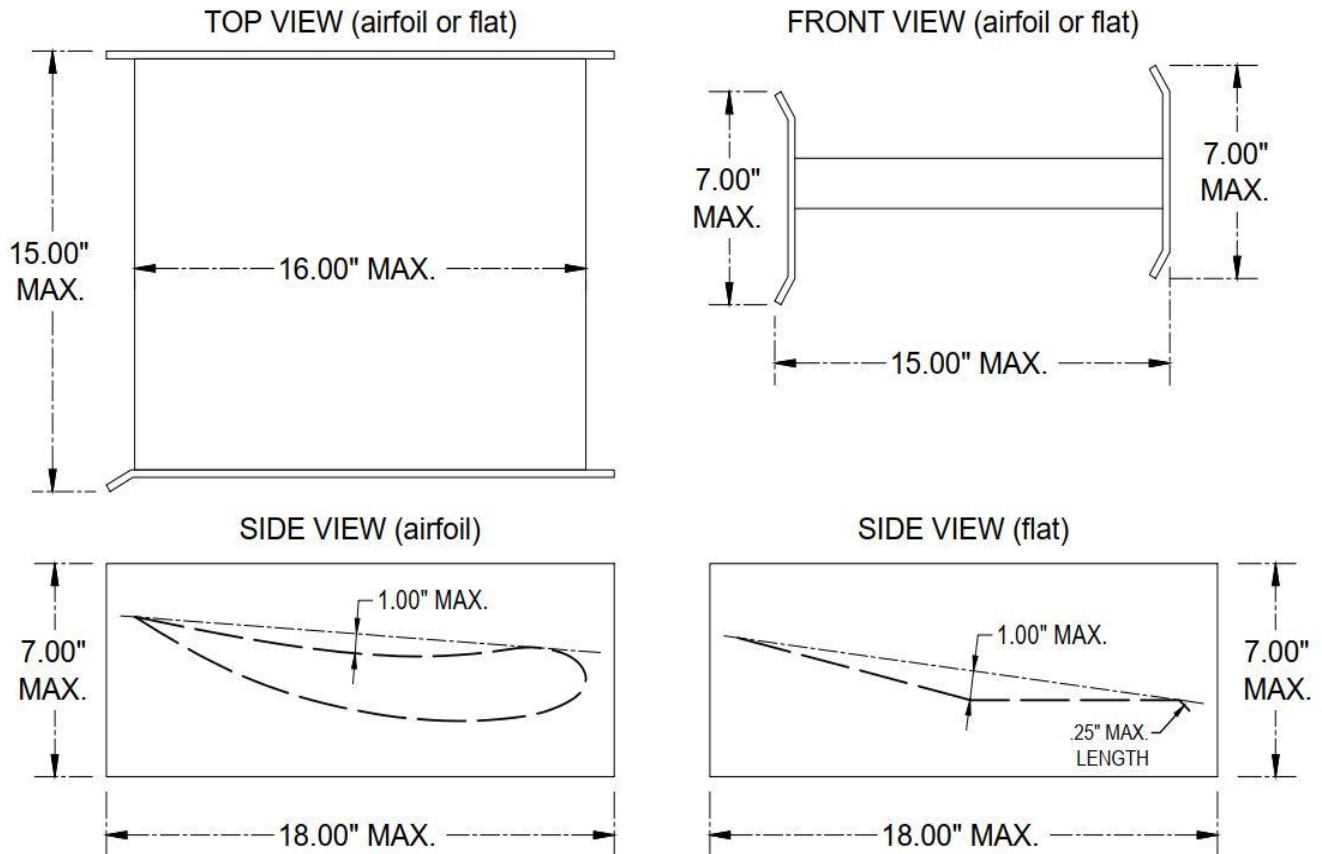

5.2. SUPER-TRUCK:

5.2.1. Rear Spoiler height: 5.0" maximum.

DIRT TRACK RULES ADDENDUM CHANGE RECORD:

2021-06-28

SECTION 5., BODY, WING, AND SPOILER SPECIFICATIONS

UPDATED/CORRECTED IMAGE TITLED "TOP WING- DIRT TRACK", SPECIFICALLY THE UPPER RIGHT IMAGE TITLED "FRONT VIEW (airfoil or flat)" BY CHANGING THE VALUE FOR THE OVERALL WIDTH FROM "14.00" MAX." TO "15.00" MAX."

REASON FOR THE CHANGE: WHEN THE ORIGINAL IMAGE WAS CREATED, THE SIDE VIEW WAS CORRECTLY LABELED WITH "15.00" MAX.", BUT THE FRONT VIEW HAD BEEN INCORRECTLY LABELED AS "14.00" MAX.". THIS CHANGE MAKES THE TWO IMAGES MATCH ONE ANOTHER AS WELL AS MATCH WHAT IS LISTED IN THE BODY OF THE DOCUMENT.

2022-03-19

1. - RE-WORDED THE FIRST SENTENCE FOR CLARITY. THE ORIGINAL SECOND SENTENCE WAS BROKEN OFF INTO A NEW LINE ITEM.

4.1.5. AND 4.1.5.1 - REMOVED IN THEIR ENTIRETY. THIS WAS REDUNDANT WITH THE STANDARD RULES PACKAGE

NEW 4.1.5., 4.1.5.1, 4.1.5.2, and 4.1.5.3 - ADDED CLARIFICATION REGARDING THE CLEANING OF DIRT TRACK RACING TIRES; ONLY WITH WATER, AS WELL AS SPECIFYING THAT SOAP, DETERGENT OR CHEMICAL AGENTS ARE NOT ALLOWED, AND TRACTION ADDITIVES ARE NOT ALLOWED.

4.2., 4.2.1., 4.2.2., 4.2.3., and 4.2.4. ARE COMPLETELY NEW

ADDED WATERMARK TO THE DOCUMENT

QSAC USE ONLY - DO NOT COPY