

TECHNICAL SPECIFICATIONS: SPRINT CAR

CHASSIS

Car must resemble a "World of Outlaws" or "USAC" Sprint Car and meet all dimensional specifications as shown below:

HEIGHT; WHEELBASE; LENGTH

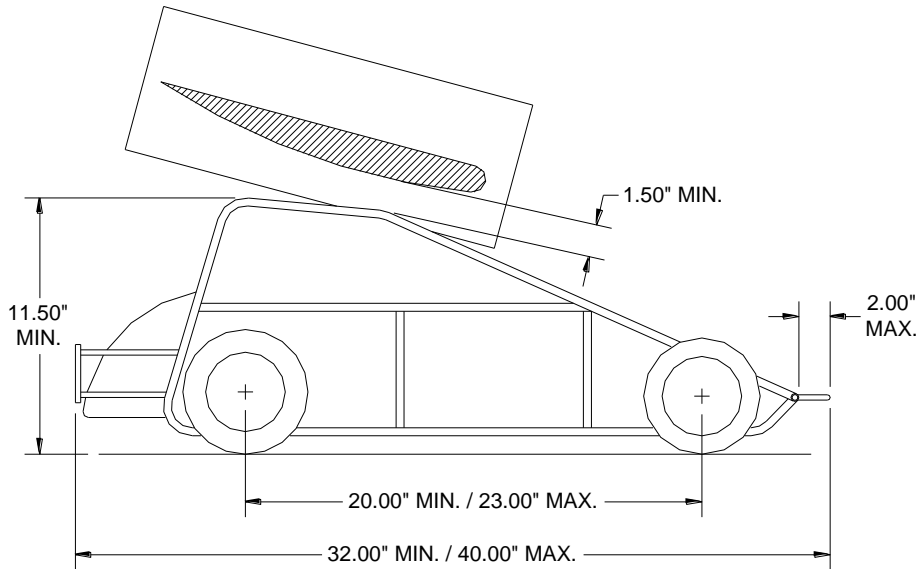

TRACK WIDTH

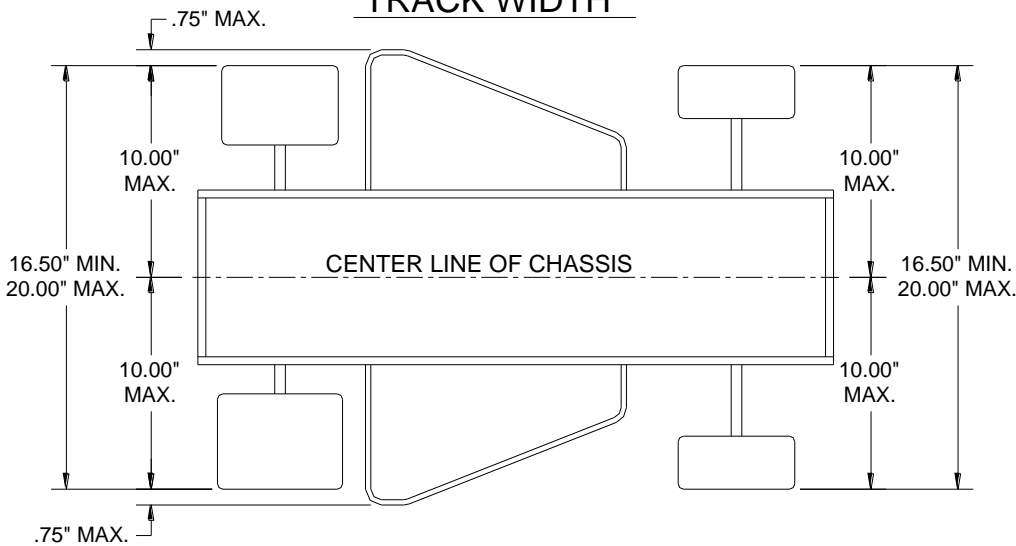

WEIGHT:

22 pounds minimum (empty fuel tank).

SUSPENSION & DRIVETRAIN

All cars must be straight axle, front and rear. This is to mean no independent suspension.

Suspension may be Coil Over and/or Torsion Bar.

Maximum of (4) shock absorbers.

Rear End Differentials (ball diffs, floater hubs) are allowed but not required.

Quick Change Gear Rear Ends (Skellenger, New Era, etc.) are allowed but not required.

BODY & WINGS

A scale appearing hood, tail tank, and top wing are required. Front wing is optional.

Top wing must be mounted so that the bottom surface of the top wing (point closest to the top of the cage) is a minimum of 1.50" above the roll cage.

No side foils, rudders, or panels are to extend beyond rear cage support bars.

Wings may be constructed of any material but must be flexible with no sharp edges.

Wings must meet all dimensional specifications as shown below:

TOP WING

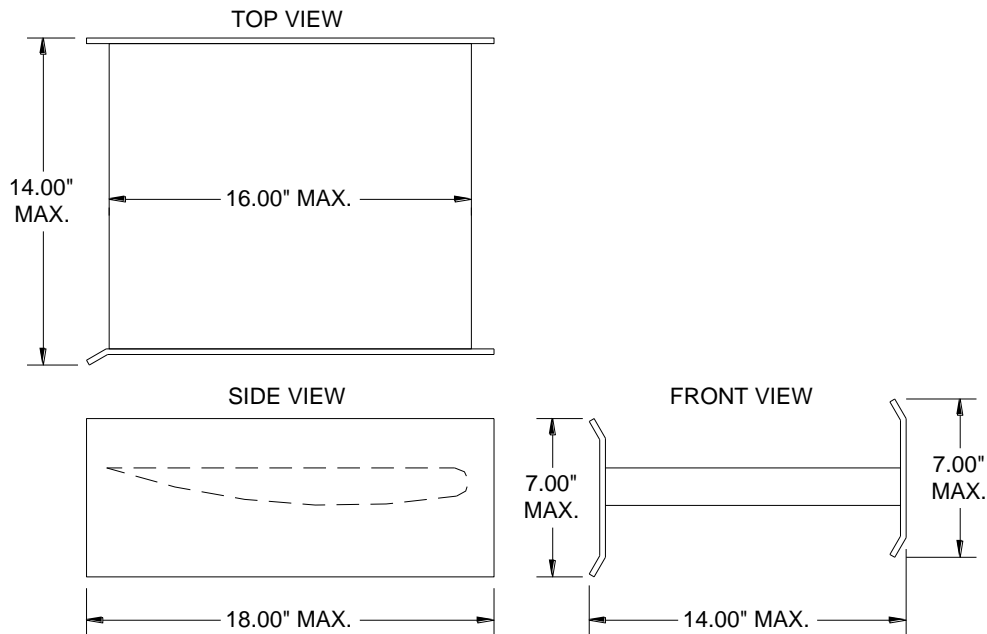

FRONT WING

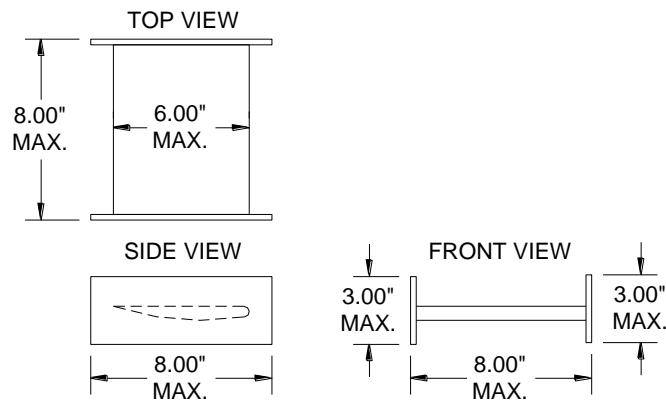

BUMPERS AND NERF BARS

Nerf Bars are required on both the left and right side of the car and must be scale appearing. Nerf Bars may extend up to .75" past the outside edge of tires.

Front Bumper is recommended but not required. If used; must be scale appearing, not to exceed the width of the main frame rails, and not to extend more than 2" from the front of the main frame.

Rear Bumper is required and must be scale appearing.

If during a race the bumpers or nerf bars are damaged in an accident to the point of being a hazard to other competitors, the parts can be removed to finish the race but must be on the car as required to start the race.

CAR NUMBERS

Car numbers must appear on outside of the top wing sideboards and both sides of the tail tank. Numbers must be a minimum of 3" high and clearly visible from the scoring stand during races.

SCORING TRANSPONDERS

Scoring transponders (personal or track transponder) must be mounted behind the center line of the front axle.

ENGINE

Must conform to all ENGINE requirements under the QSAC GENERAL SPECIFICATIONS.

Allowed Engines:

Zenoah G23RC/G230RC (versions A & B)

Zenoah G2D-70 (both two-ring and single-ring versions)

EXHAUST

Must conform to all EXHAUST requirements under the QSAC GENERAL SPECIFICATIONS.

Stock Zenoah Mufflers only. Tuned expansion chamber exhaust systems, "pipes", etc. are NOT allowed.

Exhaust may be redirected by use of a piece of 1.00 inch (ID) or larger hose or tube. Hose or tube that extends past the outside perimeter of the basic chassis must be located below the top main chassis rail (not the roll cage), within the perimeter of the right and left side nerf bar, and must not extend past the rear axle. Body panels that extend down the bottom frame rail can be trimmed to accommodate exhaust systems clearance.

CARBURETOR

Must conform to all CARBURETOR requirements under the QSAC GENERAL SPECIFICATIONS.

The Walbro WY-1 Series, (-1, -16, etc) or the Walbro WYK Series (32, 51,194) carburetors are allowed with a 10.5 restrictor / adaptor plate, two gaskets mandatory and no sealant. See page 20 (look under Carburetors for ordering information) The plates are mandatory.

CLUTCH

Must conform to all CLUTCH requirements under the QSAC GENERAL SPECIFICATIONS.

FUEL

Gasoline only per QSAC GENERAL SPECIFICATIONS.

FUEL SYSTEM

Maximum 8 oz. capacity fuel tank and will be mounted within the perimeter of the main frame rails.

All fuel lines and filler lines must be .125" inch maximum ID.

Maximum fuel line length of 30 inches which includes a maximum of two .125 inch ID x .50 inch OD x 1.25" long fuel filters, fill, feed, return and vent lines. Tubing located inside the fuel tank is excluded from this measurement.

WHEELS / RIMS

All wheels / rims must be scale appearing.

Wheel Diameter (measured at the bead):

All wheels must be 3.50" minimum / 4.00" maximum diameter

Wheel Width (measured at the bead):

Left Front: 2.00" minimum / 2.75" maximum width

Right Front: 2.00" minimum / 2.75" maximum width

Left Rear: 2.50" minimum / 3.00" maximum width

Right Rear: 3.00" minimum / 4.00" maximum width

Minimum 2 lugs per wheel.

Knockoff style wheels and hubs are allowed but not required.

TIRES

Sprint Cars must use the QSAC approved right front tire-bands. Approved compounds for all tires are the same as the Stockcar and Super Truck classes as described in the TIRES AND WHEELS requirements under the QSAC GENERAL SPECIFICATIONS.

Spike tires are allowed for dirt use only.

Sidewall / Host Width:

Left Front Host: 2.00" minimum / 2.875" maximum width

Right Front Host: 2.00" minimum / 2.875" maximum width

Left Rear Host: 2.50" minimum / 3.75" maximum width

Right Rear Host: 3.00" minimum / 4.50" maximum width

Tread / Band Width:

Left Front: 2.00" minimum / 2.75" maximum width

Right Front: 2.00" minimum / 2.75" maximum width

Left Rear: 2.50" minimum / 3.25" maximum width

Right Rear: 3.00" minimum / 4.00" maximum width

Tire Circumference:

The Right Rear tire must have a minimum circumference (rollout) of 17" before and after race.

Unless otherwise listed, all requirements from the QSAC GENERAL SPECIFICATIONS apply.